

JS Squared



- Sidh Gurnani
- José E. Guzmán
- Stefan Steyn
- Jeffrey Woodhouse



Problem Statement/Background

- Many complaints about getting in and out of lofted beds
- Climbing over the desk is dangerous and difficult
- There is a need for a device to make using lofted beds easier and safer



Agenda

- Phase Progression Overview
- Design presentation
- Phase 3 Prototype
- Engineering Analysis Overview
- Design Conclusions
- Backup Slides

Phase Progression—Key Takeaways, Phase 1

- Added ladder needed to more safely get into Bedloft beds
- Much bigger problem on campus than originally thought

JS^2 Project Tasks and Milestones	Week 1					Week 2					Week 3					Week 4					Week 5				
	M	T	W	R	F	M	T	W	R	F	M	T	W	R	F	M	T	W	R	F	M	T	W	R	F
Team organization			█	█	█																				
Project selection			█	█	█	█	█																		
Customer Research						█	█	█	█	█	█														
Intellectual property										█	█	█	█												
Personas												█	█	█	█	█									
Develop HoQ												█	█	█	█	█	█	█	█	█	█	█	█	█	
Human Centered Design																		█	█	█	█	█	█	█	
Paper #1 Introduction												█	█	█	█										
Paper #1												█	█	█	█	█	█	█	█	█	█	█	█	█	
Oral Report #1																				█	█	█	█	█	

Phase 2

- Finalized design
- Heavy manufacturing and retail cost
- Profitable design

JS^2	Week 6					Week 7					Week 8					Week 9					Week 10				
Project Tasks and Milestones	M	T	W	R	F	M	T	W	R	F	M	T	W	R	F	M	T	W	R	F	M	T	W	R	F
Group Eval #1	█	█	█																						
Paper #1	█	█	█																						
Functional Decomposition			█	█	█	█	█	█	█																
Generate Concepts			█	█	█	█	█	█	█	█															
Bill of Materials										█	█	█	█	█	█	█	█	█							
Paper #2 Plan	█	█	█	█	█	█	█	█	█	█															
October Break											█	█	█												
Financial Analysis																		█	█	█					
Low Fidelity Prototype																		█	█	█	█	█	█		
Oral Report #2	█	█	█	█	█	█	█	█	█	█	█	█	█	█	█	█	█	█	█	█	█	█	█	█	█
Paper # 2											█	█	█	█	█	█	█	█	█	█	█	█	█	█	█

Phase 3

- Models indicate a necessity for a return to design
- Prototype indicates viability of design on size criteria

JS^2 Project Tasks and Milestones	Week 11					Week 12					Week 13					Week 14					Week 15				
	M	T	W	R	F	M	T	W	R	F	M	T	W	R	F	M	T	W	R	F	M	T	W	R	F
Group Eval #2	█	█	█																						
engineering drawings			█	█	█	█	█	█																	
modeling/final prototype			█	█	█	█	█	█	█	█	█	█	█	█	█	█	█	█	█	█	█	█	█		
poster	█	█	█	█	█	█	█	█	█	█	█	█	█	█	█										
Final oral presentation			█	█	█	█	█	█	█	█	█	█	█	█	█	█	█	█	█	█	█	█	█	█	█
Group Eval #3																									█
final paper			█	█	█	█	█	█	█	█	█	█	█	█	█	█	█	█	█	█	█	█	█		
final presentation													█	█	█	█	█	█	█	█	█	█	█	█	█

Design Description

3 stage folding
ladder

Cheapest and easiest to
manufacture while still
being easy to use

Rubber feet on
bottom

Good grip to the floor
and spreads load to not
damage floor, very easy
and cheap to
manufacture

Rung spacing and
width determined
OSHA

CAD Models

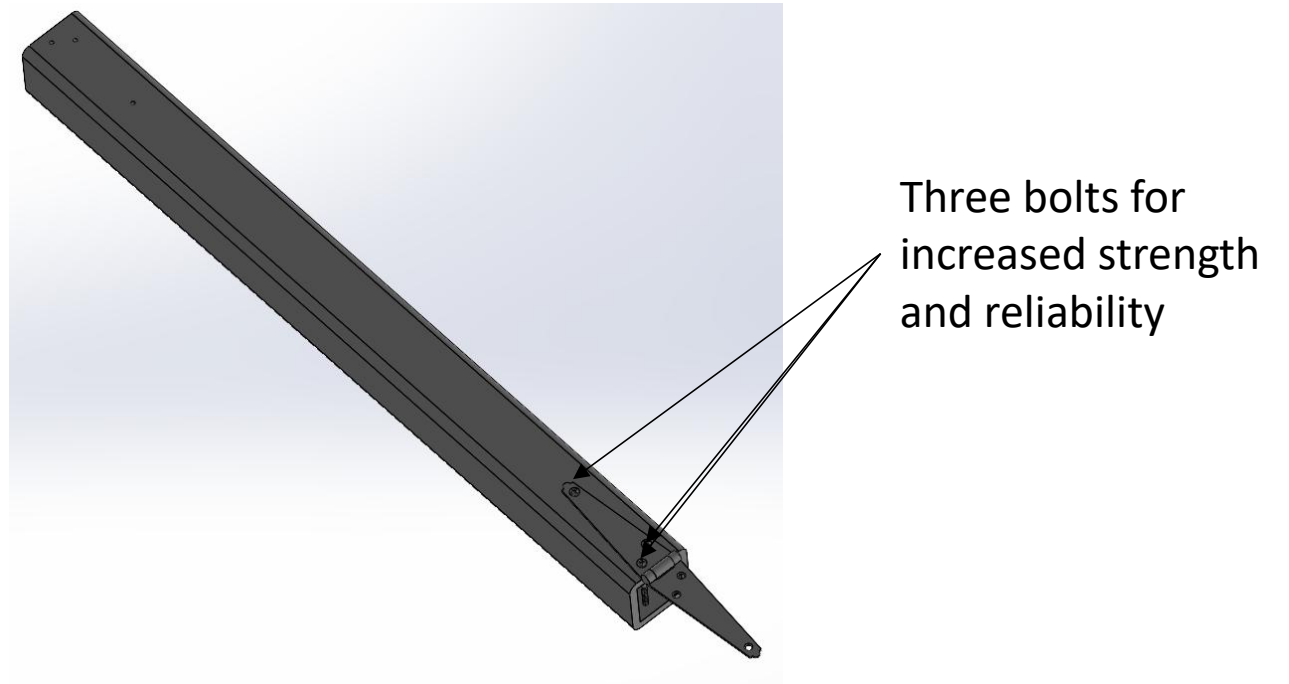
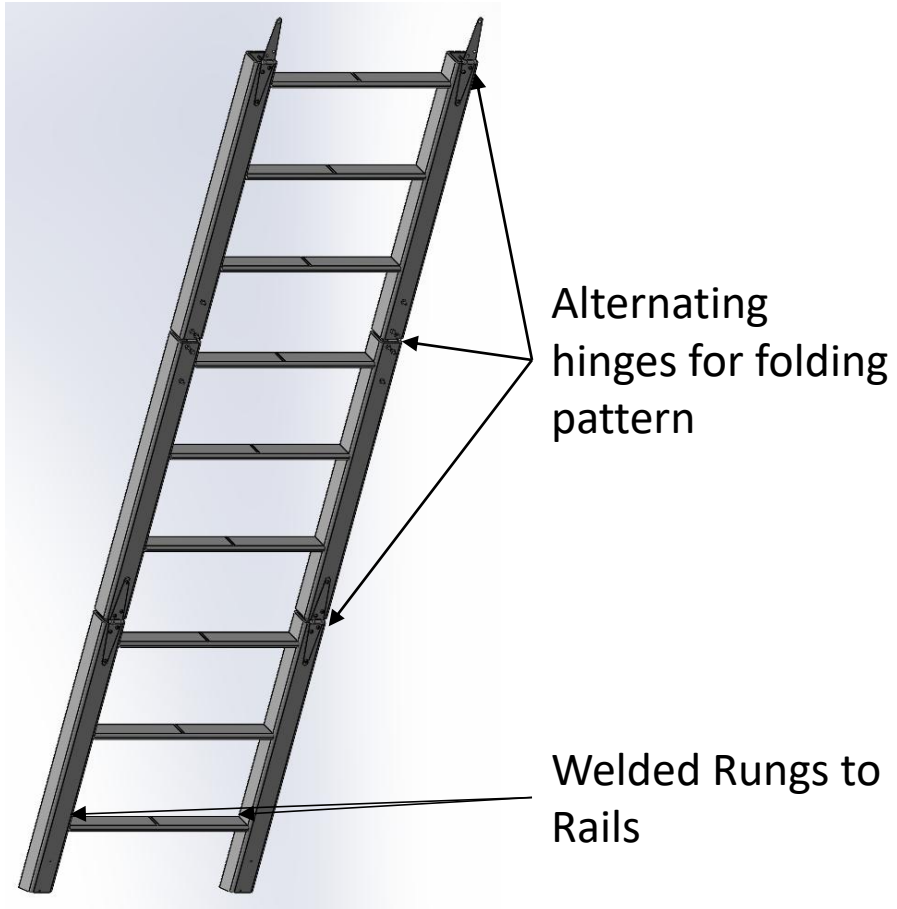

Prototype



Lessons Learned/Step-by- Step guide

- Ladder will take longer to manufacture than originally thought
- More pins are required to hold the ladder in stored position
- Better understanding of how ladder works and is stored with physical model

Engineering Analysis → Thermal Stress

- Varying temperature from 0-50 Celsius with applied 300lb load assuming ambient temperature of 22 Celsius
- Ladder will be able to withstand the 300lb force anywhere in that temperature range

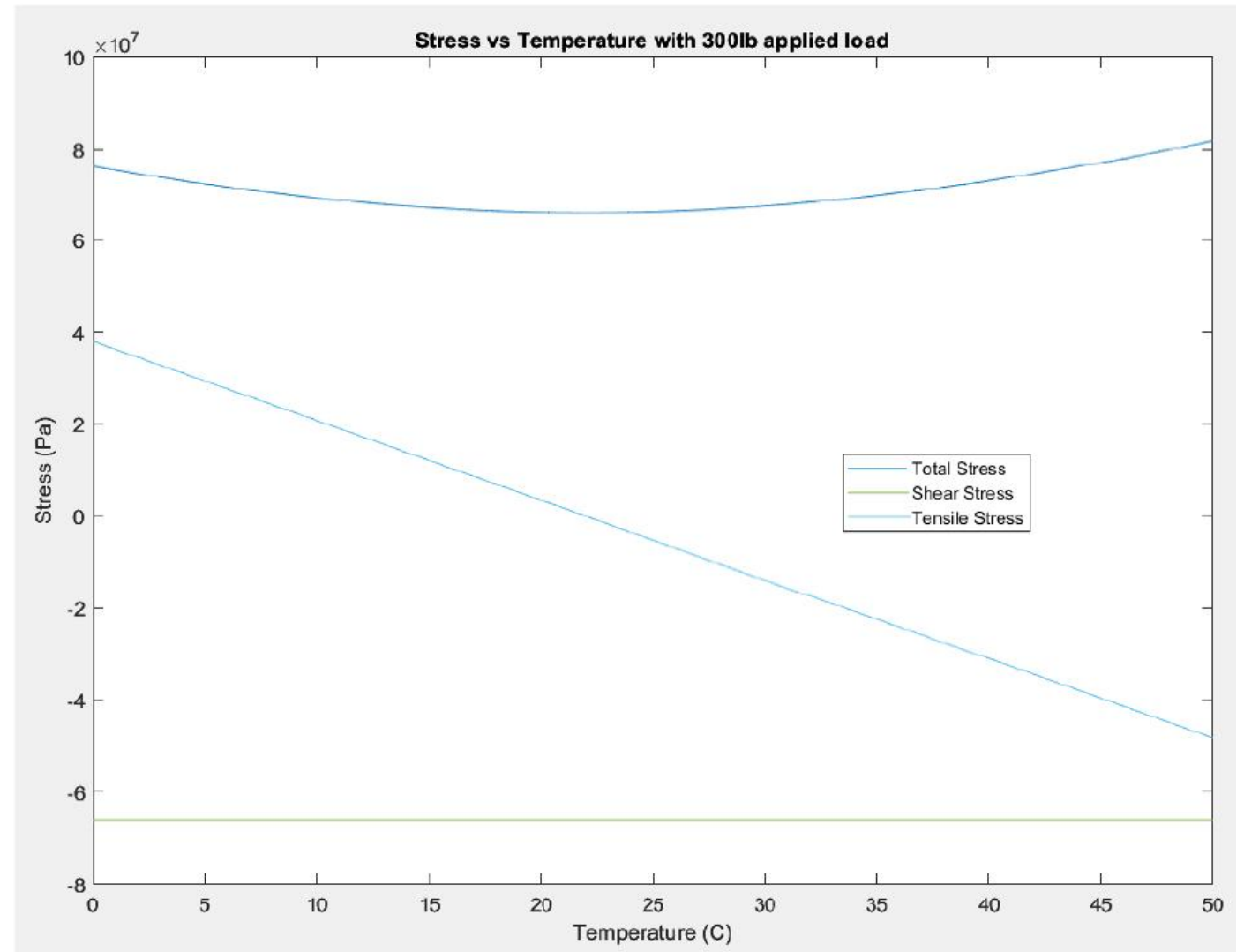

Engineering Analysis → Rung Deflection

- Deflection is greatest when person steps in center of rung
- Strong support at sides of rung
- To improve the design the team can add a structure to support the center of each rung

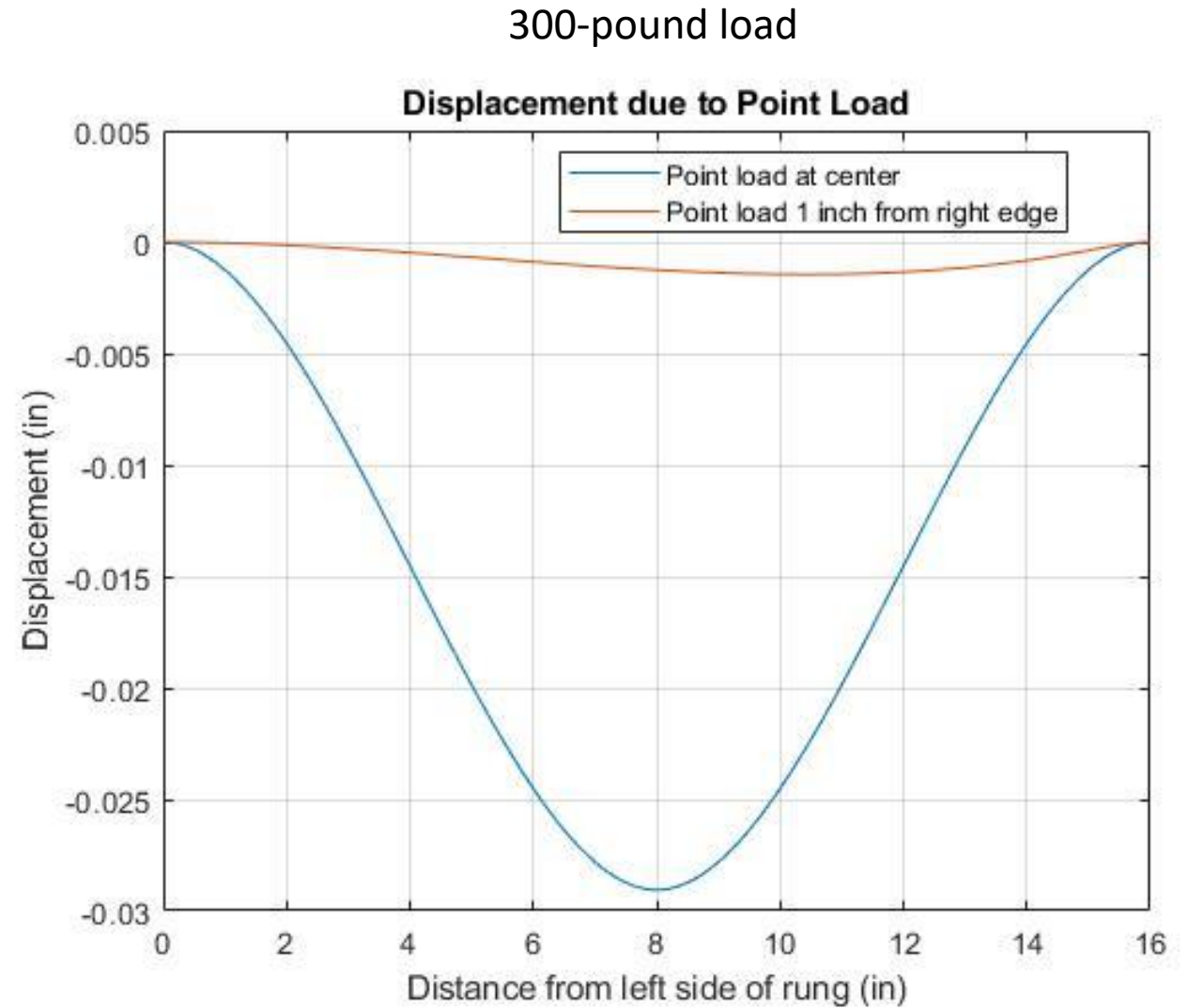

Engineering Analysis → Stow Force

- Indicates that initial force to move ladder will be the most difficult
- Should redesign ladder so path of force is shorter and requiring less force

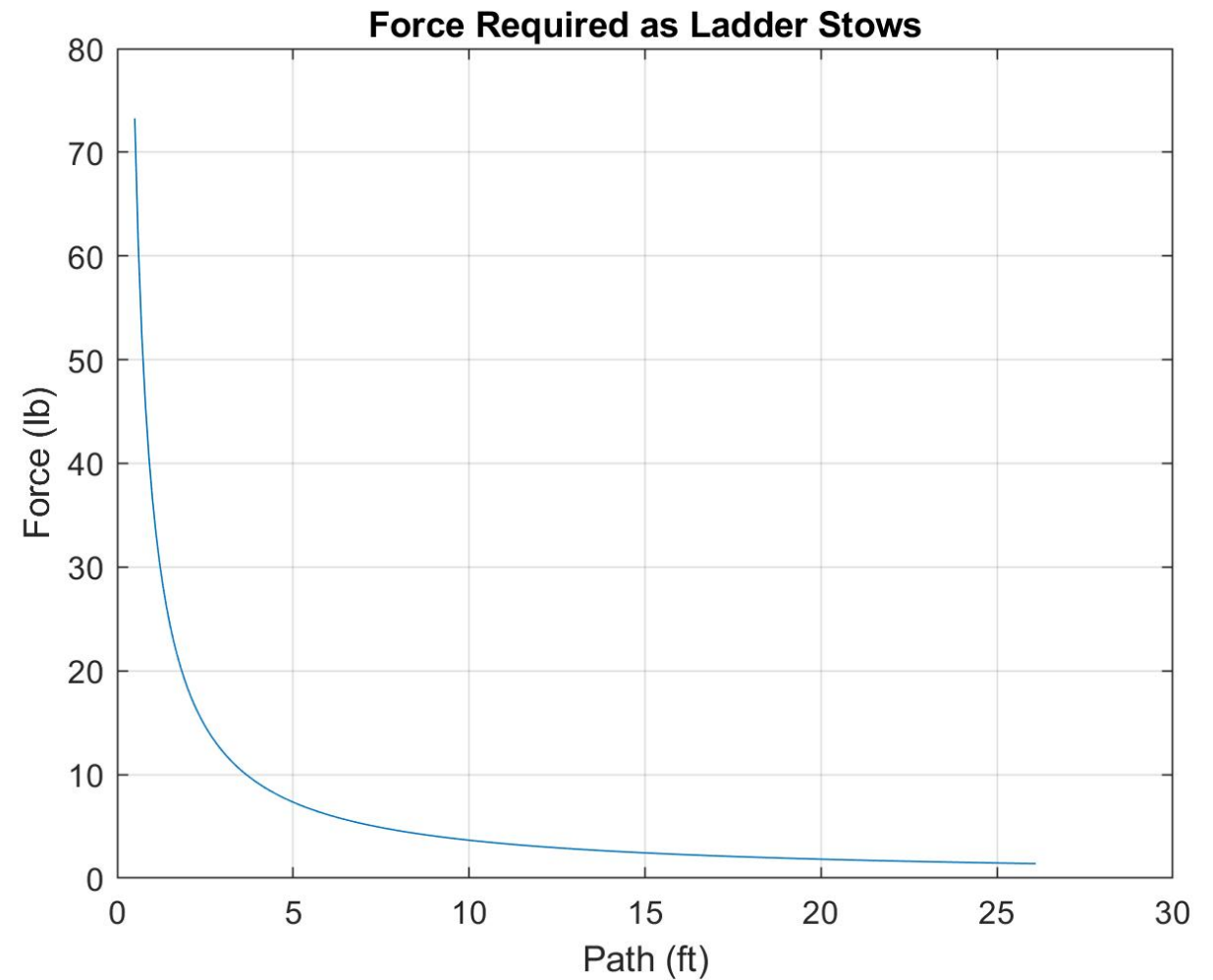

Engineering Analysis → Shear Force and Bending Moment

Shear Force Graph

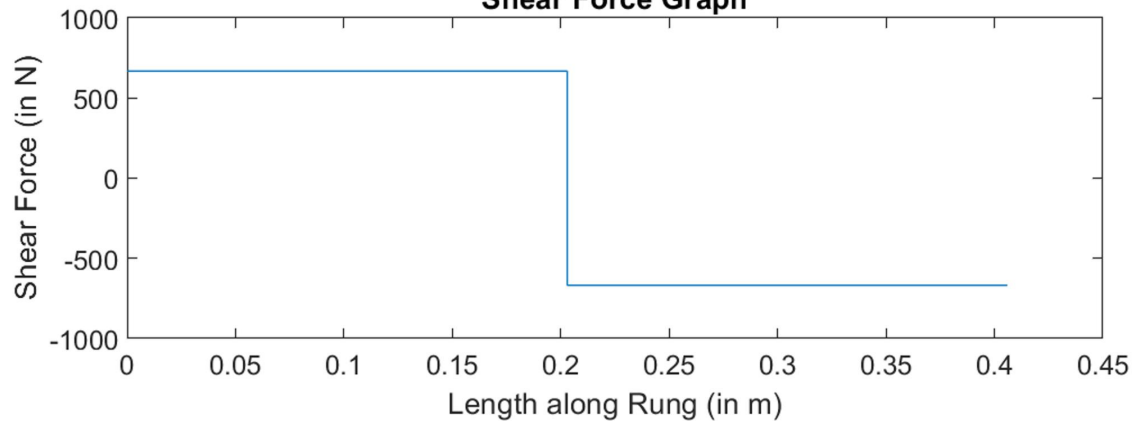

Bending Moment Graph

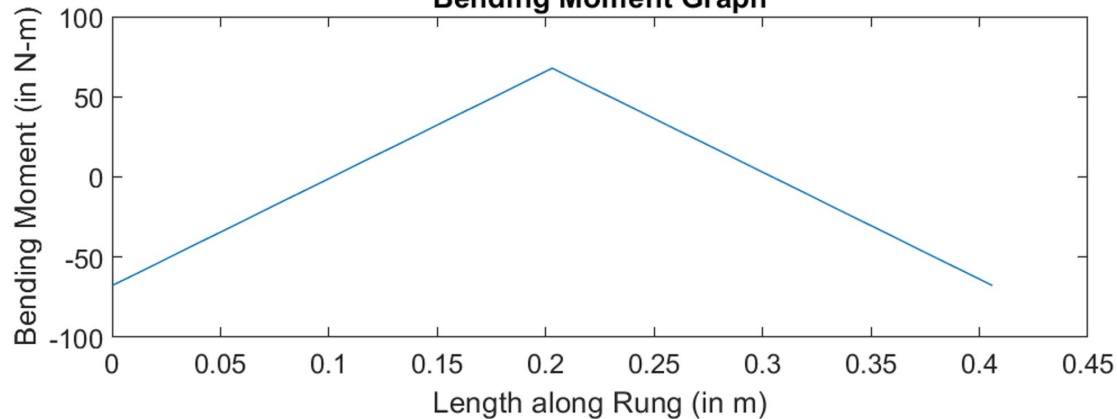

- **Assumptions:**

- User is 300 pounds
- Force is applied at exactly one point in the center of the rung

- **Key Findings:**

- Left half of the rung has a positive shear force and an increasing bending moment
- Right half has a negative shear force and a decreasing bending moment
- Peak of bending moment occurs where there is a large negative shear force
- Gives insight into the nature of the internal forces and moments, which is as expected

Design Conclusions

Key Engineering Specifications

Met:

- Takes up $< 2 \text{ ft}^3$ of space
- Weigh at most 30 lbs.
- Sets an angle between 60 and 80 degrees

Unmet:

- Supports at least 300 lbs.

Key Customer Requirements

Met:

- Set at angle
- Doesn't take up much space
- Lightweight
- Ladder folds

Unmet:

- Designed to limit pinching
- Stable to climb
- Not too many steps to use

Design Conclusions-Benchmark Comparisons

- Things that were done well (compared to the benchmarks):
 - Our solution was designed with OSHA ladder requirements in mind, which encompasses rung spacing, and rung size
- Things that can be made better:
 - System that folds the ladder can be made more compact so that it takes up less space
 - Focus on designing a solution that will not pinch hands
 - Can be made more stable to climb
 - Complex compared to the benchmarks with respect to number of steps to use

Design Conclusions-Future Improvement

- Next prototype can be made from aluminum
- Set hinge better into ladder rails to limit pinching hazard
- Angle cut ladder rails that connect with floor and add rubber
- Lessen tooling cost
- Redesign pin system to be more intuitive

Backup Slides

Overview of Market Research

- Market is wide open since Bedloft is the sole supplier to over 50 schools
- ~155,000 beds
- Goal is to deliver to 20% of the market over 3 year production period

Problem Definition Update

- Problem Definition remains unchanged from Phase One
 - A solution is needed to help people who rent Bedloft lofted beds get in and out of bed easier
 - Sturdy (supports at least 300 pounds)
 - Small(< 2 ft³)
 - Hangs at an angle(60-80 degrees)
 - Doesn't pinch user

Problem Definition

- House of Quality analysis resulted in the identification of critical qualitative requirements and engineering specifications for a solution to the Bedloft problem
- JS² proposes a **folding ladder design** that hangs under the lofted bed

Problem Definition

Qualitative Requirements

- Light enough for a normal person to use
 - Not too many steps to use
 - Doesn't take up too much space
 - Won't pinch hands when used
 - Does not wobble or shake when climbed
- Must not be perfectly vertical
 - Must be able to support most weights
 - The device must be aesthetically low profile when stowed
 - The device must utilize a locking mechanism that prevents unintended activation
 - The device must not break with typical usage

Problem Definition

Engineering Specifications

- Weigh at most 30 pounds
 - Store volume at most 2 feet cubed
 - Rung spacing between 8 and 12 inches
 - Angle made with floor between 60 and 80 degrees
 - Supports at least 300 pounds
- Installable in under 20 minutes
 - Lifespan of at least 10 years
 - Rung width between 16 and 18 inches
 - Must wholesale for \$90 or less
 - Operable between 0°F and 100°F

Problem Definition

Engineering Specifications

- Meets OSHAA General Requirements 29 CFR 1910.23(b)(5) – (10) – pinching hazards
- 4 or less steps to use device
- Flame resistant
- Made of material with ultimate tensile strength of at least 90 Mpa*
- Made of a material with a Young's modulus of elasticity of at least 11 Mpa*







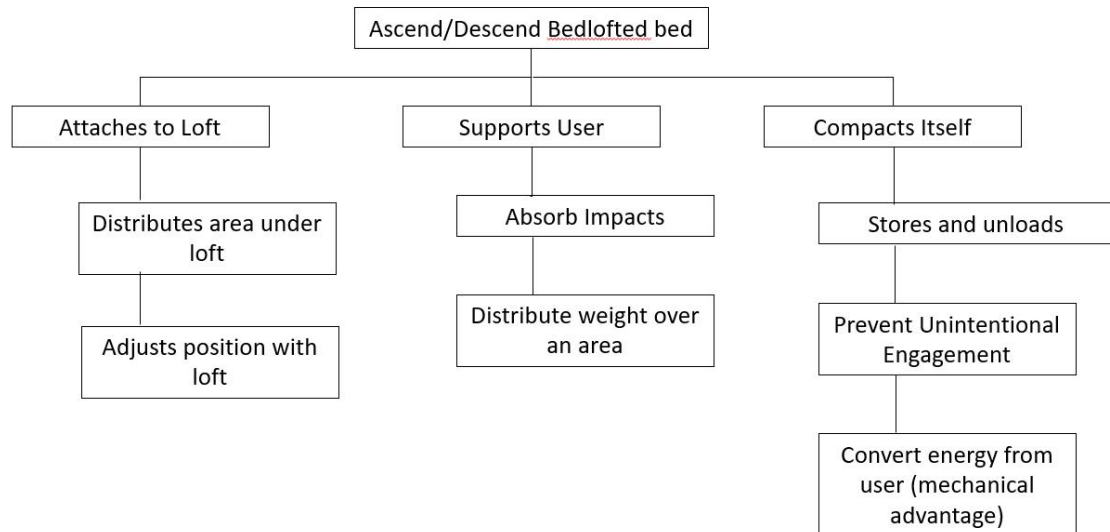

- Material has shear modulus of elasticity of at least 26 GPa*
- Material has bulk modulus of elasticity of at least 76 Gpa*
- Material has brinell hardness should be at least 240 MPa *
- Material has vickers hardness of 167 MPa *
- Material has a coefficient of static friction of no more than 1.05 - 1.35 with itself*

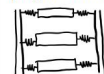
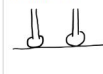
*Aluminum is our benchmark for these specifications

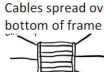
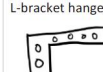
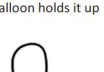
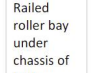
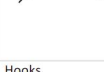
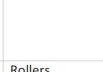
Concept Generation

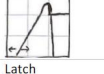
- Defined 7 sub-sub-functions from main function using function decomposition
- Defined 2-4 solutions for each sub-sub-function
 - Example: storing and unloading:
 - Sliding
 - Folding
 - Telescoping

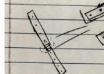
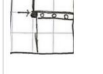

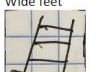
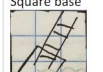
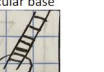
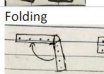
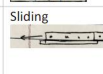
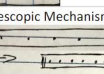
Sub-Function	Morphological Chart Solutions			
	1	2	3	4
Absorbs impact	Spring loaded steps 	Rubber feet 	Elastic steps 	
Distributes area under the loft	Cables spread over bottom of frame 	L-bracket hangers 	A balloon holds it up 	Railed roller bay under chassis of bed 
Adjust position with loft	Hooks 	Rollers 	Bolts 	Slides 
Prevent unintentional engagement	Latch 	Pin 		
Distribute weight over an area	Wide feet 	Square base 	Circular base 	
Stores and unloads	Folding 	Sliding 	Telescopic Mechanism 	
Convert energy from the user	Long lever arms 	Pulley system 	Rollers 	

Concept Selection

- Each member drew four unique designs based on different solutions for each sub-sub-function
- Each team member chose their best/most reasonable design to be compared

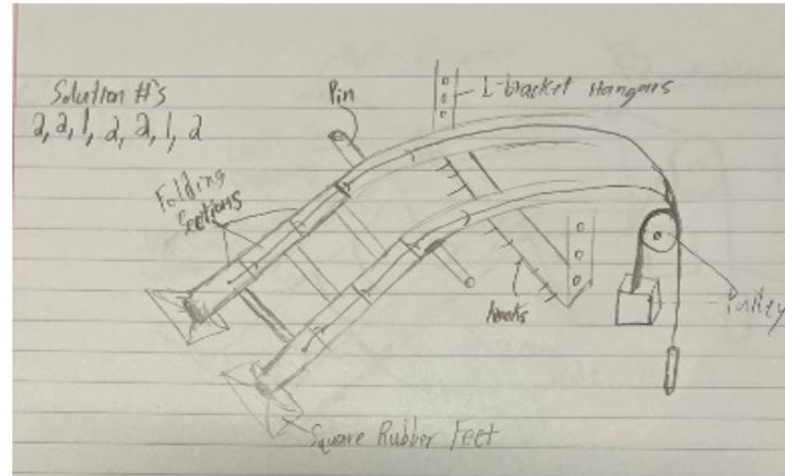

2212212

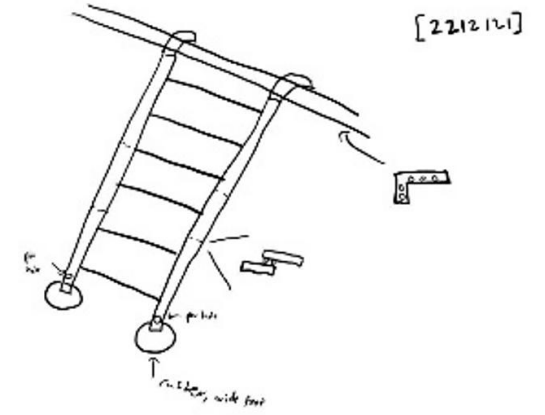

2212121

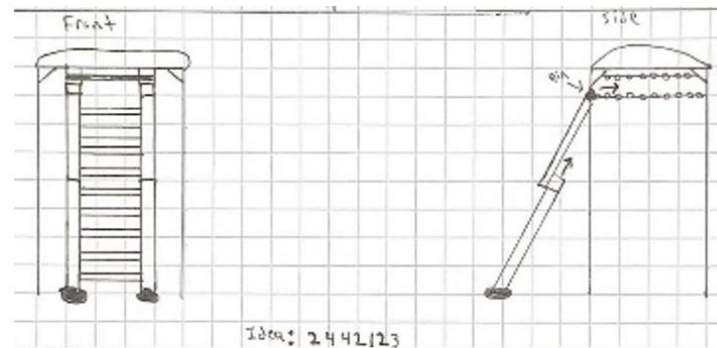

2442123

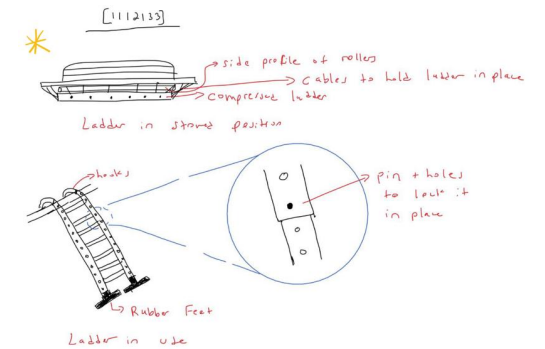

1112133

Design Matrix

CUSTOMER REQUIREMENTS	WEIGHTS	CONCEPTS				
		Concept 2442123	Concept 2212121	Concept 1112133	Concept 2212212	DATUM Concept Bedloft Ladder
Less than 4 steps to store	4	1	0	0	1	0
Small volume when stored	7	-1	-1	0	-1	0
Mechanism has minimal steps to use	6	1	0	0	0	0
Looks natural in a room	5	-1	-1	-1	0	0
Must have wide enough rungs for feet	6	1	1	1	1	0
	Weighted Total	18	16	15	17	0

Final Concept

- Each member selected their best/most realistic solution, and each of those 4 solutions was compared to each other and a final solution was selected
 - Round, rubber feet
 - Folding mechanism
 - Pins with L-brackets
 - Long lever arms for mechanical advantage

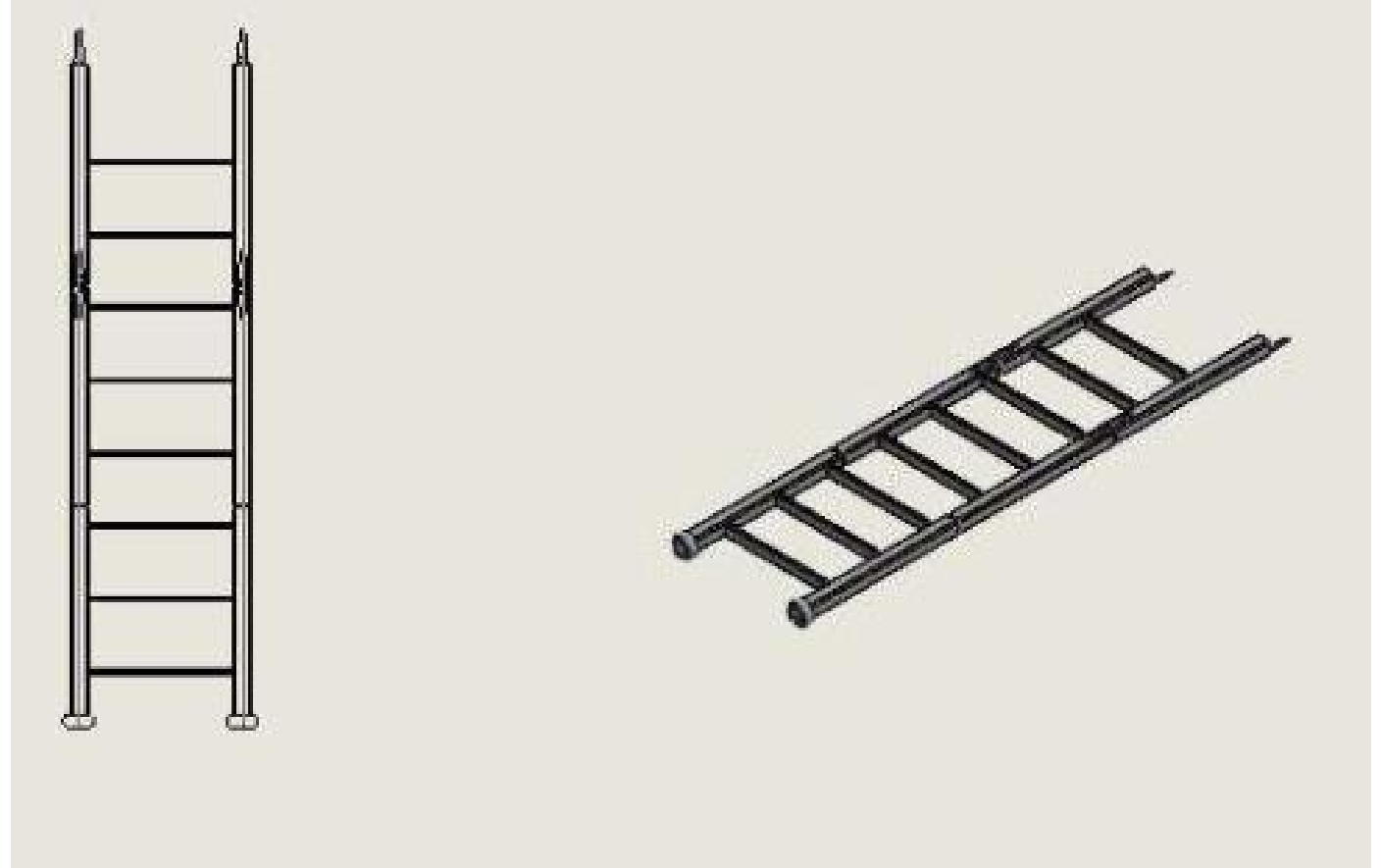

Comparison to Relevant Benchmarks

*For brevity, some data is omitted, but totals are representative of all customer requirements looked at.

Customer Requirements	Our Solution	Built-in Ladder	Stow Step	Desk	Regular Ladder
Less than four steps to store	5	5	5	1	4
Small volume when stored	4	4	5	1	2
Can be used without pinching hands	5	4	3	3	4
Doesn't wobble or shake when in use	4	3	5	3	4
Mechanism has minimal steps to use	5	5	5	3	4
Steps are not too far apart	5	2	1	1	4
Won't cause injury if bumped into	3	4	3	3	4
Must have wide enough rungs for feet	5	5	2	5	4
Can be installed in reasonable amount of time	5	5	4	4	3
Totals	75	63	65	50	62

Low Fidelity Prototype

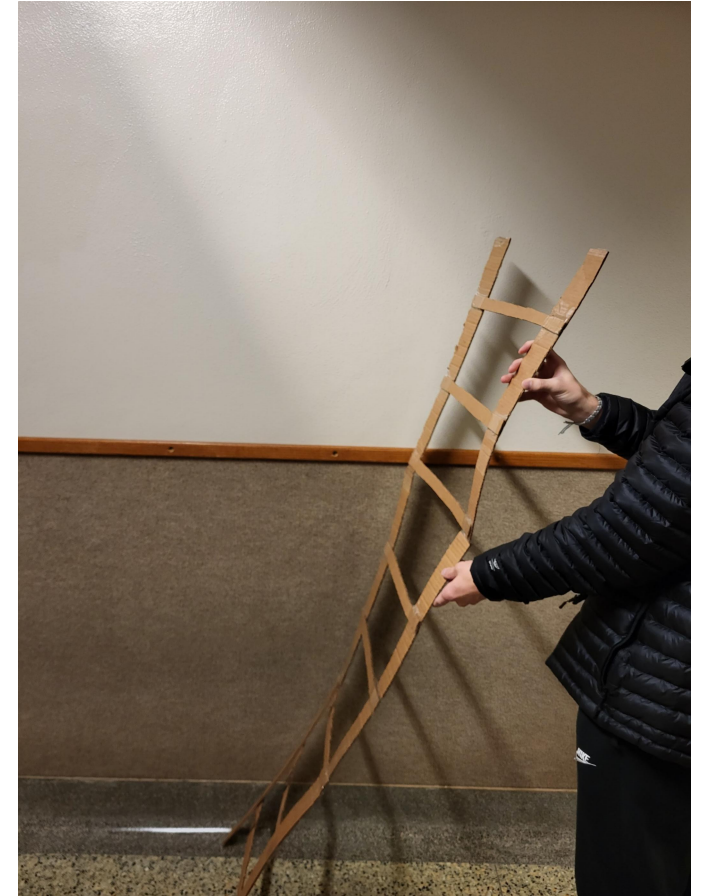
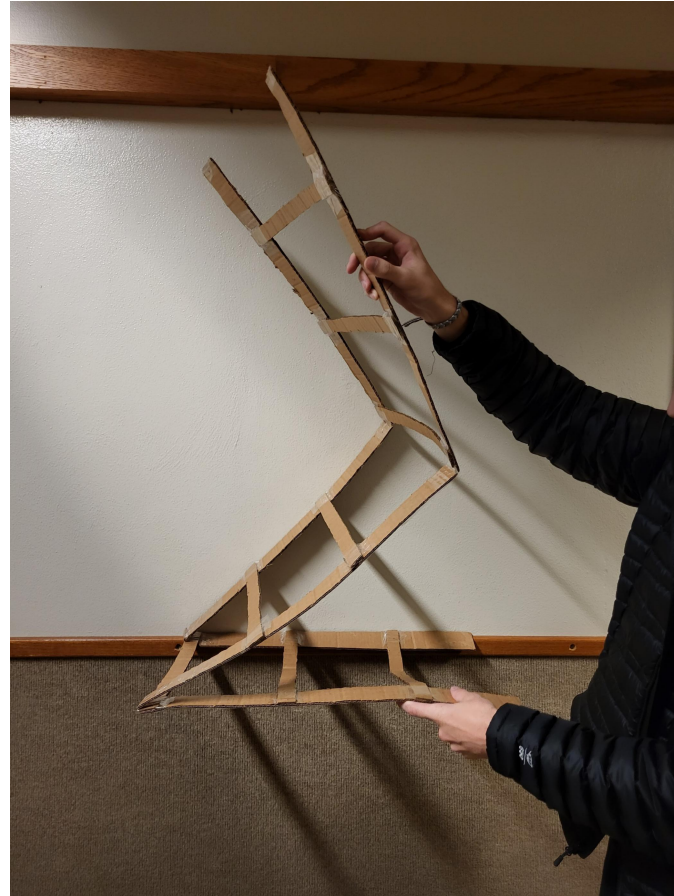

Bill of Materials

Item No.	Part No.	Part Name	Units	Qty	Material / Description	Source	Catalog No.	Unit Cost (\$)	Unit Processing Cost (\$)	Assembly Cost (\$)	Line Total Cost (\$)
1	A1	Final Assembly	-	1	Final Assembly of Hanging Ladder	-	-	-	-	\$ 10.00	\$ 10.00
2	A2	Ladder Assembly	-	3	Assemble Ladder Sections	-	-	-	-	\$ 10.00	\$ 30.00
3	P1	Rubber feet	pcs	2	Rubber	McMaster	1370N55	\$ 0.09	-	-	\$ 0.18
4	P2	Hinge	pcs	6	allow ladder to fold/unfold	McMaster	1526A51	\$ 0.74	-	-	\$ 4.44
5	P3	Bolts	pcs	36	6-32 2"	McMaster	91772A161	\$ 0.05	-	-	\$ 1.80
6	P4	Nuts	pcs	36	6-32"	McMaster	91841A007	\$ 0.01	-	-	\$ 0.36
7	P5	Ladder Rungs	pcs	2	Steps for climbing 6' long 2"x.5"	McMaster	89215K127	\$ 47.56	-	-	\$ 95.12
8	P6	Pin	pcs	2	Pin sections in place	McMaster	98381A482	\$ 0.75	-	-	\$ 1.50
9	P7	Anti Slip Tape	ft	11	make rungs less slippery	McMaster	6244T51	\$ 0.40	-	-	\$ 4.40
10	P8	L-bracket	pcs	2	Allows ladder to be attached to frame	McMaster	1558A23	\$ 1.73	-	-	\$ 3.46
11	P9	Ladder Rails	pcs	2	Rectangular Tubing 6' long 2"x2"	McMaster	6546K27	\$ 44.79	-	-	\$ 89.58
12	P10	L-bracket bolts	pcs	6	0.25"x0.5"	McMaster	91772A537	\$ 0.08	-	-	\$ 0.48
13	M1	Cut rubber	-	-	Cut the rubber for the feet	-	-	-	\$ 2.00	-	\$ 2.00
14	M2	Drill Holes	-	-	Holes for hinge mounting on rails	-	-	-	\$ 5.00	-	\$ 5.00
15	M3	Round Rails	-	-	Rounding corners rails 1/4" fillet	-	-	-	\$ 10.00	-	\$ 10.00
16	M4	Cut Rungs	-	-	Cut rungs to 16" length	-	-	-	\$ 5.00	-	\$ 5.00
17	M5	Round Rungs	-	-	Round corners on rungs 1/4" fillet	-	-	-	\$ 10.00	-	\$ 10.00
18	M6	Cut Rails	-	-	2' rail section cuts	-	-	-	\$ 5.00	-	\$ 5.00

Total Purchased Parts \$ 201.32

Total Custom Manufactured Parts \$ 32.00

Total Assembly Cost \$ 40.00

Total Cost \$ 273.32

BOM – Purchased Parts

- Total: \$201.32

Part Name	Units	Qty	Material / Description
Rubber feet	pcs	2	Rubber
Hinge	pcs	6	allow ladder to fold/unfold
Bolts	pcs	36	6-32 2"
Nuts	pcs	36	6-32"
Ladder Rungs	pcs	2	Steps for climbing 6' long 2"x.5'
Pin	pcs	2	Pin sections in place
Anti Slip Tape	ft	11	make rungs less slippery
L-bracket	pcs	2	Allows ladder to be attached to f
Ladder Rails	pcs	2	Rectangular Tubing 6' long 2"x2'
L-bracket bolts	pcs	6	0.25"x0.5"

BOM – Purchased Parts

- Total: \$201.32

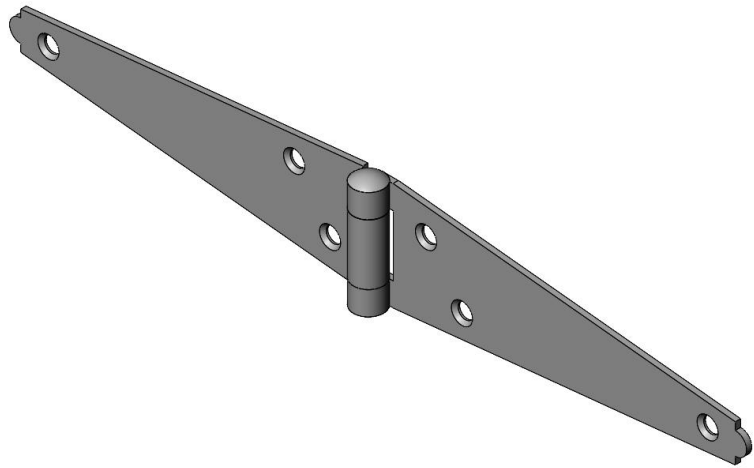

Hinge

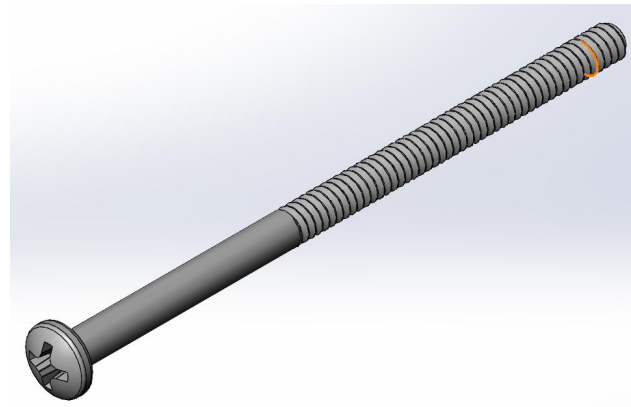

Bolt

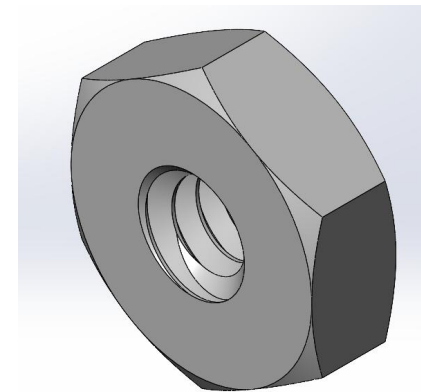

Nut

BOM – Manufacturing Operations

- Total: \$32.00

Item No.	Part No.	Part Name	Units	Qty	Material / Description	Unit Processing Cost (\$)
13	M1	Cut rubber	-	-	Cut the rubber for the feet	\$ 2.00
14	M2	Drill Holes	-	-	Holes for hinge mounting on rails	\$ 5.00
15	M3	Round Rails	-	-	Rounding corners rails 1/4" fillet	\$ 10.00
16	M4	Cut Rungs	-	-	Cut rungs to 16" length	\$ 5.00
17	M5	Round Rungs	-	-	Round corners on rungs 1/4" fillet	\$ 10.00
18	M6	Cut Rails	-	-	2' rail section cuts	\$ 5.00

BOM – Manufacturing Operations

- Total: \$32.00

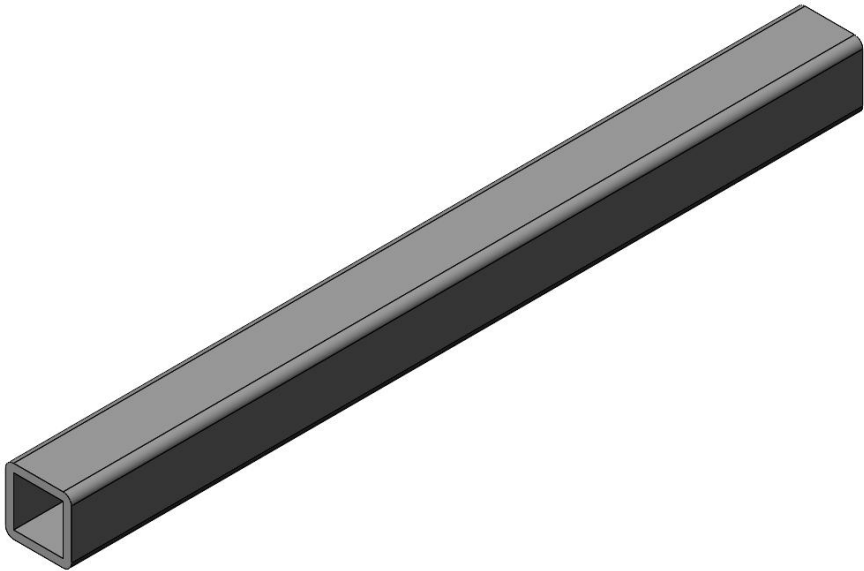

Ladder Rail

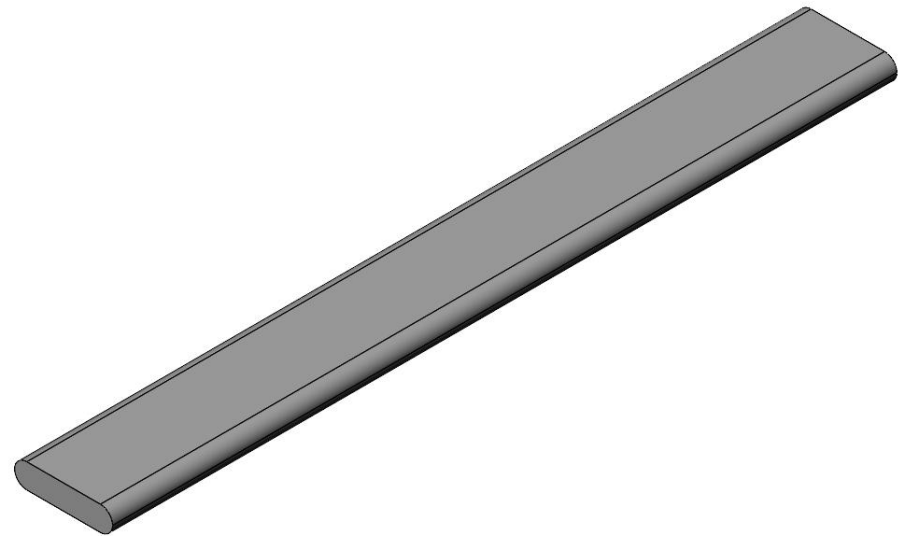

Ladder Rung

BOM – Assembly Costs

- Total: \$40.00

Item No.	Part No.	Part Name	Units	Qty	Material / Description	Assembly Cost (\$)
1	A1	Final Assembly	-	1	Final Assembly of Hanging Ladder	\$ 10.00
2	A2	Ladder Assembly	-	3	Assemble Ladder Sections	\$ 10.00

BOM – Assembly Costs

- Total: \$40.00

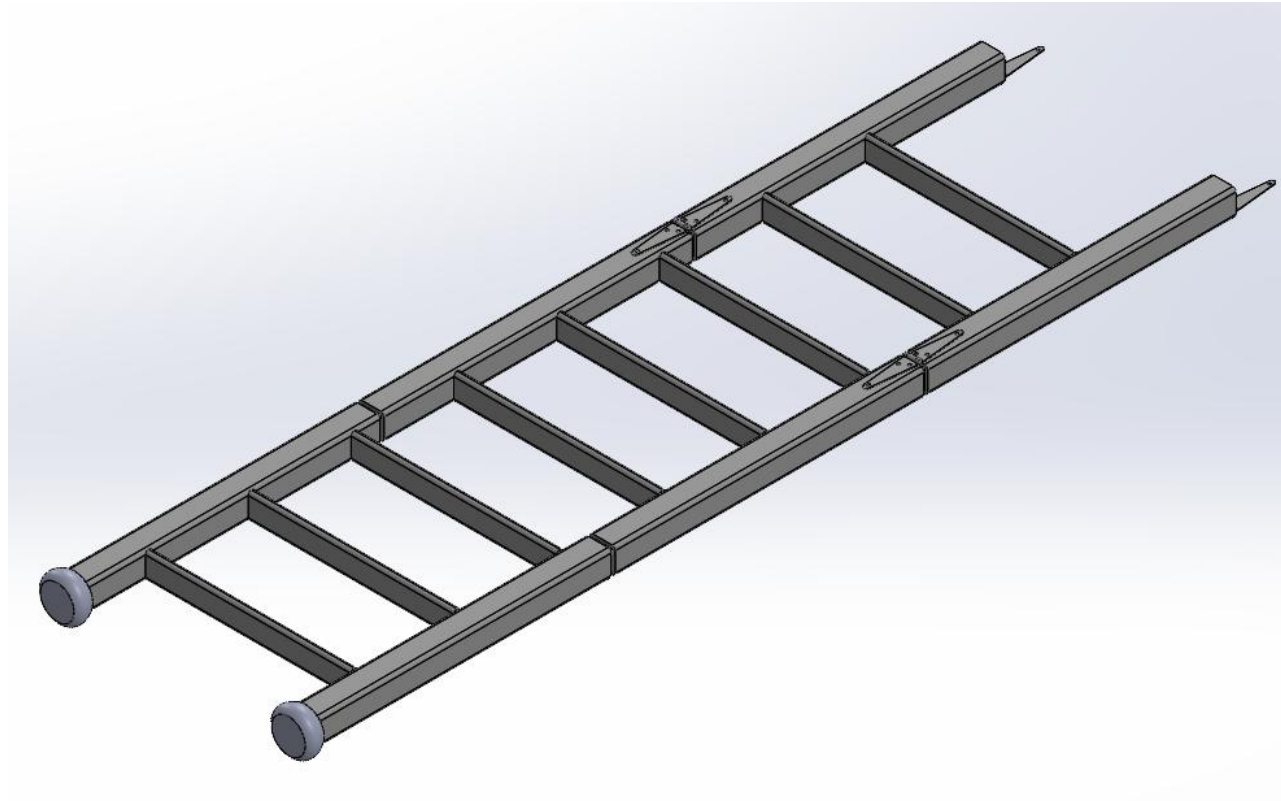

Final Assembly Version 1

Economical Analysis

- Total Cost Associated with Direct Labor

Overhead Cost Calculations

Number of employees	4 people
Wage	19.23077 \$/hr
Total pay	11538.46 \$
Direct Labor Cost	46153.85 \$
Social Security	2861.538 \$
Medicare	669.2308 \$
Federal Unemployment	224 \$
State Unemployment	756 \$
Worker's Compensation	2000 \$
Business Insurance	2000 \$
Medical Insurance	16000 \$
Rent	12000 \$
Utilities	4000 \$
Total Overhead Cost	40510.77 \$

General and Administrative Cost Calculations

Payroll Accounting	800 \$
Accounting/Legal	2000 \$
Office Expenses	1200 \$
Telephone	2400 \$
Internet Fee	2400 \$
Computer and software Expenses	4800 \$
Miscellaneous Expenses	4000 \$
Total G&A	17600 \$
Total Cost Associated	104264.6 \$

Economical/Financial Analysis

- Tooling and Fixture Cost of \$410,000
- R&D Cost of \$132,2646
- Annual Production of 10,000 units a year.

Spreadsheet For Project Economic Evaluation

Input																	CALCULATED		
Interest Rate / year =	8 %															Interest Rate per Period =	0.020		Rate/period
Analysis Periods / year =	4 #															Estimated Mfg. Cost =	273.32		\$
Tooling and Fixtures =	410 000															Retail Price =	1093.28		\$
Annual Production =	10 000															Build per period =	2.5 000		#
Estimated Purchased Parts =	201.32 \$															Total Program Build =	30 000		#
Estimated Fabricated Parts =	32 \$															Total Retail Sales =	32.7984 (10^6)		\$
Estimated Assembly Cost =	40 \$															Return to Project =	9.83952 (10^6)		\$
R&D Costs =	134.2646 000															Net Present Value =	841.3 000		\$
Cost, % of Retail =	25 %															Net Worth (excl. interest) =	1095.655 000		\$
Return to Project, % of Retail =	30 %																		

	Quarters															Sum
	1	2	3	4	5	6	7	8	9	10	11	12	13	14	15	
R&D Costs (000)	67.1323	67.1323	0	0	0	0	0	0	0	0	0	0	0	0	0	134.2646 000
Tooling & Fixtures (000)	0	205	205	0	0	0	0	0	0	0	0	0	0	0	0	410 000
Production (000)	0	0	0	2.5	2.5	2.5	2.5	2.5	2.5	2.5	2.5	2.5	2.5	2.5	2.5	30 000
Cost of Production (000)	0	0	0	683.3	683.3	683.3	683.3	683.3	683.3	683.3	683.3	683.3	683.3	683.3	683.3	8199.6 000
Plant "Sales" (000)	0	0	0	819.96	819.96	819.96	819.96	819.96	819.96	819.96	819.96	819.96	819.96	819.96	819.96	9839.52 000
Sales Minus Cost (000)	0	0	0	136.66	136.66	136.66	136.66	136.66	136.66	136.66	136.66	136.66	136.66	136.66	136.66	1639.92 000
Net for Quarter (000)	-67.1323	-272.132	-205	136.66	136.66	136.66	136.66	136.66	136.66	136.66	136.66	136.66	136.66	136.66	136.66	1095.655 000
Net Worth (000)	-67.1323	-339.265	-544.265	-407.605	-270.945	-134.285	2.3754	139.0354	275.6954	412.3554	549.0154	685.6754	822.3354	958.9954	1095.655	000
Present Value (000)	-65.8	-261.6	-193.2	126.3	123.8	121.4	119.0	116.6	114.4	112.1	109.9	107.8	105.6	103.6	101.5	841.3 000
Net Worth Present Value (000)	-65.8	-327.4	-520.6	-394.3	-270.5	-149.2	-30.2	86.4	200.8	312.9	422.8	530.6	636.2	739.8	841.3	000

ROI=	53.68 %	min production no interest=	3.32 000
ROR=	76.87 %	min production with interest=	3.82 000
PB=	8th quarter		
NPV=	841.3 \$'000		

Financial Analysis

- Estimated Manufacturing Cost of \$273.32
- Estimated Retail Price of \$1093.28
- Expected Payback in the 7th quarter
- ROI of 53.68%
- ROR of 76.87%
- NPV of \$841,300 by the 15th quarter

Input			
Interest Rate / year =	8 %		
Analysis Periods / year =	4 #		
Tooling and Fixtures =	410 000		
Annual Production =	10 000		
Estimated Purchased Parts =	201.32 \$		
Estimated Fabricated Parts =	32 \$		
Estimated Assembly Cost =	40 \$		
R&D Costs =	134.2646 000		
Cost, % of Retail =	25 %		
Return to Project, % of Retail =	30 %		

CALCULATED			
Interest Rate per Period =	0.020	Rate/period	
Estimated Mfg. Cost =	273.32	\$	
Retail Price =	1093.28	\$	
Build per period =	2.5 000	#	
Total Program Build =	30 000	#	
Total Retail Sales =	32.7984 (10^6)	\$	
Return to Project =	9.83952 (10^6)	\$	
Net Present Value =	841.3 000	\$	
Net Worth (excl. interest) =	1095.655 000	\$	

ROI=	53.68 %	min production no interest=	3.32 000
ROR=	76.87 %	min production with interest=	3.82 000
PB=	7th quarter		
NPV=	841.3 \$'000		

Financial Analysis

Net Worth (No interest)

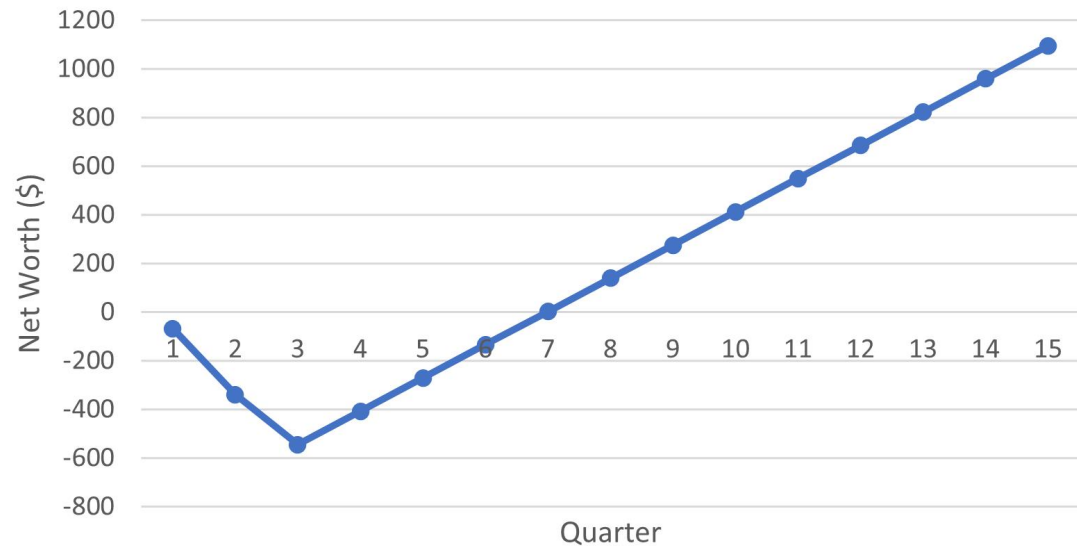

Present Value Net Worth

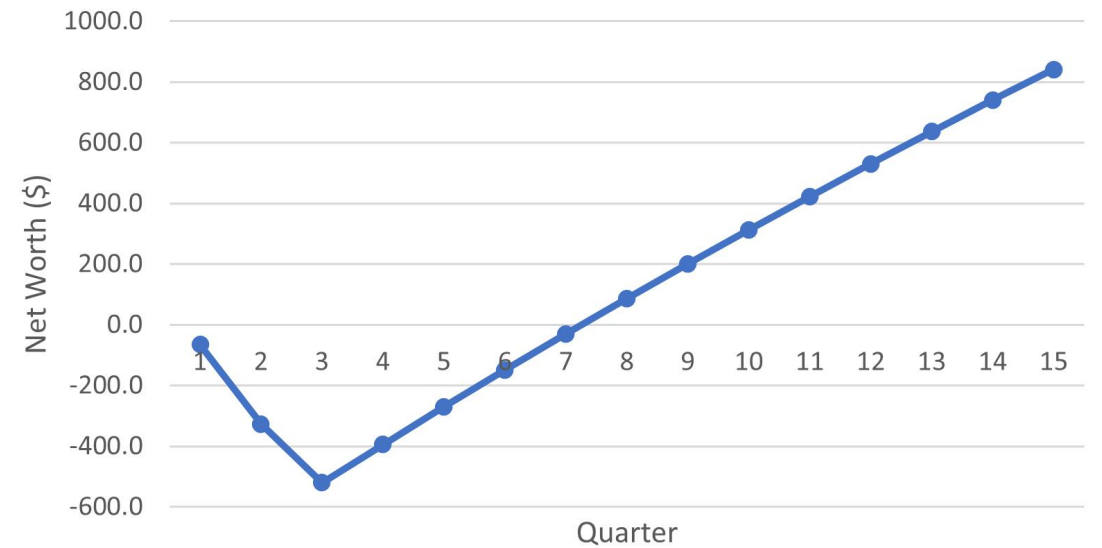

Personas

- Georgina Washington – early bird, very active, recently broke her ankle and tends to be injury prone
- Tommy Bahama – average college student, struggles to use his desk to climb in and out of his bed, worried about damaging the desk by using it in such a way
- George Davidson – avid partier, stays up late hanging out with frat brothers, some nights can't get into bed due to being too inebriated

Customer Research

- 35 responses – 32 of which had experience with lofted beds
- 53.1% of people experienced some sort of injury associated with using a lofted bed
- Average 2.9375/5 difficulty using a lofted bed
- Popular themes: ladder, stability, padding/comfort

What would make getting in and out of your lofted bed easier?

26 responses

- I am able to use the ladder on the ends of the purdue beds, but if I had to climb up my desk, I would want a ladder
- Lowering the bed
- a more stable ladder
- A ladder on the side of the bed not the back
- More stable lofts. The current ones wobble when you climb into them.
- Some kind of stairway?
- An angled ladder or something of the sort
- A ladder
- more stable bed supports

What would make getting in and out of your lofted bed easier?

26 responses

- Simple ladder
- higher ceilings, slanted ladders, handles, access from more than one point
- Having a different type of ladder/ form of getting up, also since I am naturally short, have a smaller loft bed where I am still able to put my desk under it.
- an accessible ladder
- A ladder would be nice but usually I used the extra drawer they gave us and climbed my way up
- Making the steps thicker
- I put my mattress on the ground
- More comfortable way to getting up/down (some sort of padding on the bed, etc)
- Ladder or padding of some sort

What would make getting in and out of your lofted bed easier?

26 responses

- More comfortable way to getting up/down (some sort of padding on the bed, etc)
- Ladder or padding of some sort
- Something sturdy and possibly with rails (more like step stool vibes)
- Since I'm living in a forced triple, there isn't much room to buy anything additional to climb into my lofted bed. Having a clean desk to climb would help, but I struggle to keep my desk tidy. I'm not very sure what would help to get in and out of my lofted bed.
- being able to choose where my bed ladder is (it's always too close to the wall or another bed), being able to choose how high my bed is lofted, having safety precautions on sharp edges
- Easier ladder
- A slide to go out of the bed
- stairs vs. ladder; taller ceilings

Market Research

- In the United States, Bedloft supplies to:
- 13 states, primarily Midwest
- 51 colleges
- Available up to 155,202 beds
- Max Revenue between \$12,500,000 and \$29,600,000

Number of Students Living on Campus by State

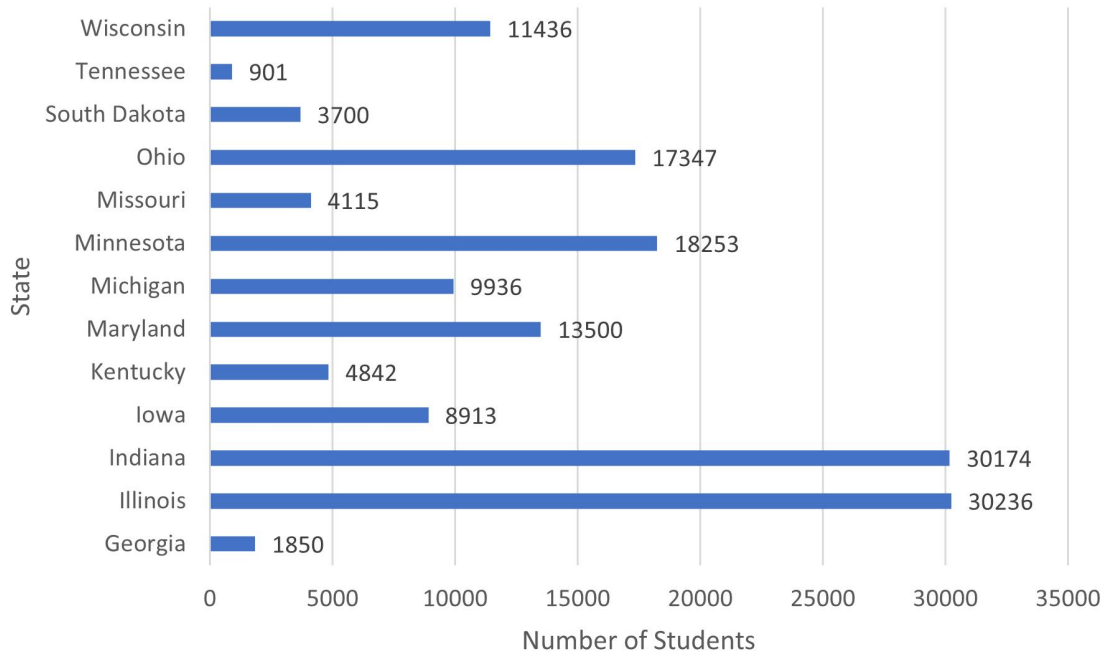

Percentage of Students Living in On-Campus Housing in Bedloft-Affiliated Schools

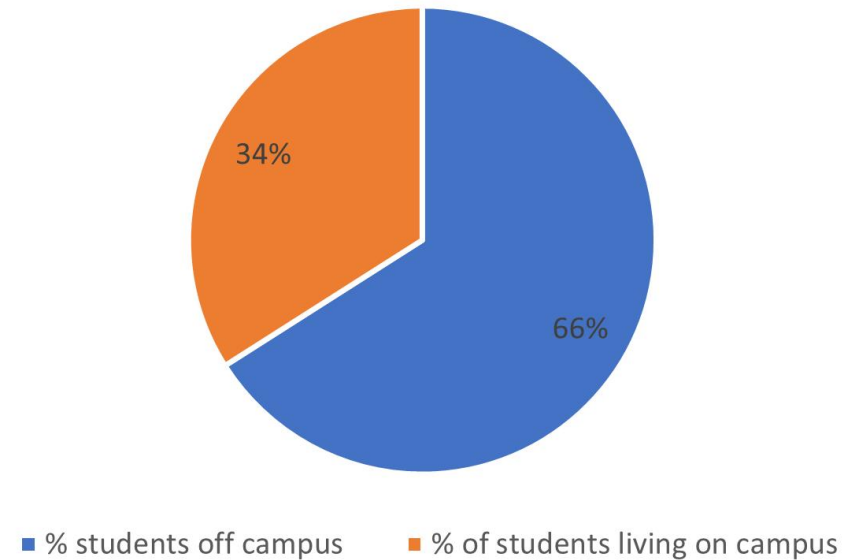

Product Research

- Bunk beds ≈ Lofted beds
- Solutions to get in and out of bunk beds

- US5003650A

- Expired

- US7832031B1

- *Valid through 7/31/2029*

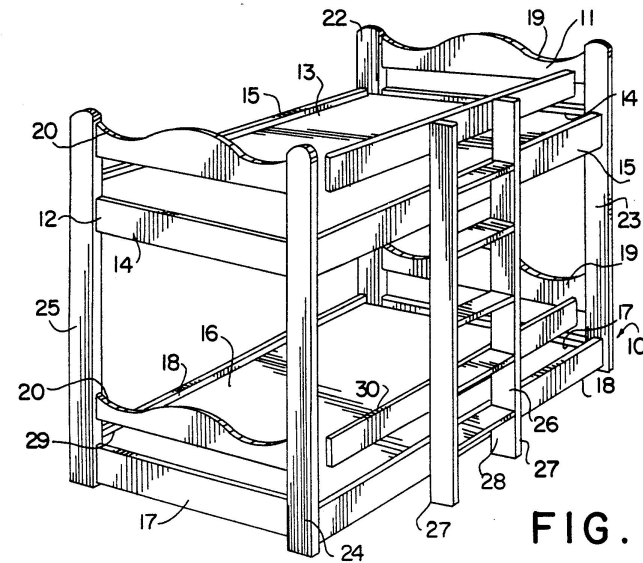
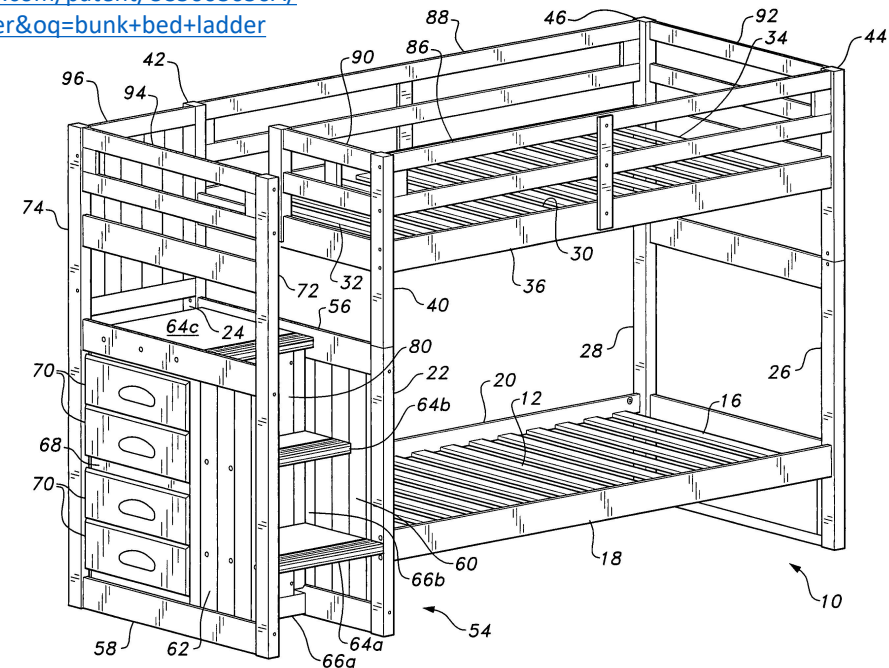

FIG. 1

<https://patents.google.com/patent/US5003650A/en?q=bunk+bed+ladder&oq=bunk+bed+ladder>



<https://patents.google.com/patent/US7832031B1/en?q=bunked+bed+ladder&oq=bunked+bed+ladder> 45

<https://patents.google.com/patent/US6994184B2/en>

Product Research (cont'd)

- Previous Solutions
 - **Safer** to use
 - **Easier** to get in and out of
 - **Not space friendly**
- What about creating something more space friendly?
 - US6994184B2
 - Valid through 12/15/2023
 - EP1728966B1
 - Valid through 6/31/2025

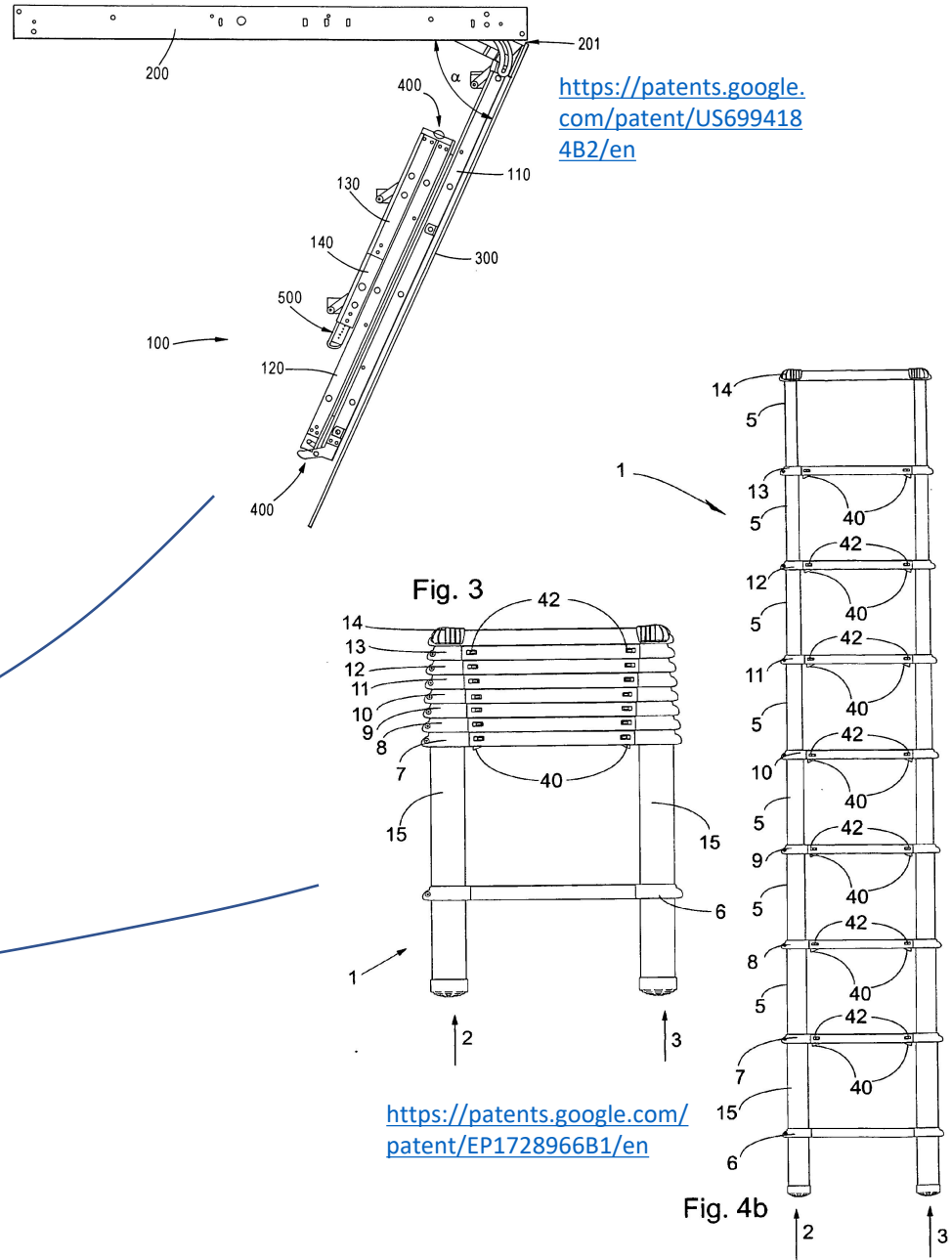

<https://patents.google.com/patent/EP1728966B1/en>

HoQ

- Benchmarks
- Problem Definition
 - Qualitative Requirements
 - Engineering Specifications

JS² House of Quality

HOUSE OF QUALITY	Who (Customers)				How (ES)													Now (Benchmarks)			
	Tommy Bahama	Georgina Washington	George Davidson	TOTAL	Weight	Under 4 usage steps	Low storage volume	Rung spacing	Angled with floor	Supported Weight	Installation time	Lifespan	Rung width	Meets OSHAA	Cost	Totals	BedLoft built in ladder	Desk	Regular Ladder	"Stow Step"	
					lbs	Y/N	ft^3	in	deg	lbs	min	years	in	Y/N	\$						
What (Customer Requirements)					↓	<->	↓	<->	<->	↑	↓	↑	<->	<->	↓						
Not too heavy for typical person to use	4	7	4	15	9		3									12	5	1	3	5	
Less than 4 steps to store	4	4	8	16		9										9	5	1	4	5	
Small volume when stored	4	4	3	11			9	1					3			13	4	1	2	5	
Can be used without pinching hands	5	6	8	19										9		9	4	3	4	3	
Won't damage floor	4	4	5	13	6									3		9	5	5	4	5	
Doesn't wobble or shake	9	9	7	25					3	6						9	3	3	4	5	
Must be angled with floor	5	5	5	15					9							9	1	1	5	N/A	
Able to support weight	9	8	7	24					1	9			3	1		14	4	5	5	4	
Mechanism has minimal steps to use	8	3	7	18		9										9	5	3	4	5	
Looks natural in a room	8	5	4	17			9									9	4	4	2	4	
Steps are not too far apart	7	7	5	19				9								9	2	1	4	1	
Won't cause injury if bumped into	7	5	8	20	6		3							9		18	4	3	4	3	
Must have wide enough rungs for feet	7	9	7	23									9			9	5	5	4	2	
Can be installed without taking too much time	4	5	5	14		1					9					10	5	4	3	4	
Installable by a normal person	4	6	5	15		1	1				9					11	3	5	2	5	
Will not break with typical usage	5	7	6	18		3				9		9		6		27	4	5	5	4	
Low cost	6	6	6	18											9	9	N/A	N/A	3	5	
Totals	100	100	100	300	21	23	25	10	13	24	18	9	15	28	9	195	63	50	62	65	

Ratings Legends:
Now vs What:
 1 = does not meet requirement
 2 = meets requirement slightly
 3 = meets requirement somewhat
 4 = meets requirement mostly
 5 = meets requirement completely

How vs What:
 blank (=0), 1, 3, 9

Who vs What:
 weights summing to 100

Importance	333	389	372	182	234	528	261	162	312	522	162	<= sum of the products of TOTAL Column entry and Corresponding ES entry
Importance (Ranking)	5	3	4	9	8	1	7	10	6	2	10	
Bedloft built in ladder	N/A	y	0	6	90	1000	0			y	0	<= these are values for ES in proper units
Desk	100	y	10	15			5			y	0	
Regular Ladder	20	y	3	8	75		2		16	y	100	
"Stow Step"	10	y	0	8	90	300	10		10	n	50	
Target (Delighted)	25	y	2	8	75	300	10	50	18	y	90	
Threshold (Disgusted)	65	n	4	12	60/90	200	30	10	16	n	150	

HoQ: Benchmarks

- Bedloft Built-In Ladder
 - No extra weight, 90° with floor
- Desk
 - Able to support weight, very heavy
- Regular Ladder
 - Able to support weight, additional cost
- Stow Step
 - Small volume when stored, potential to cause injury when bumped into

HOUSE OF QUALITY	Now (Benchmarks)			
	BedLoft built in ladder	Desk	Regular Ladder	"Stow Step"
What (Customer Requirements)				
Not too heavy for typical person to use	5	1	3	5
Less than 4 steps to store	5	1	4	5
Small volume when stored	4	1	2	5
Can be used without pinching hands	4	3	4	3
Won't damage floor	5	5	4	5
Doesn't wobble or shake	3	3	4	5
Must be angled with floor	1	1	5	N/A
Able to support weight	4	5	5	4
Mechanism has minimal steps to use	5	3	4	5
Looks natural in a room	4	4	2	4
Steps are not too far apart	2	1	4	1
Won't cause injury if bumped into	4	3	4	3
Must have wide enough rungs for feet	5	5	4	2
Can be installed without taking too much time	5	4	3	4
Installable by a normal person	3	5	2	5
Will not break with typical usage	4	5	5	4
Low cost	N/A	N/A	3	5
Totals	63	50	62	65

Ratings Legends:

Now vs What:
 1 = does not meet requirement
 2 = meets requirement slightly
 3 = meets requirement somewhat
 4 = meets requirement mostly
 5 = meets requirement completely

How vs What:
 blank (=0), 1, 3, 9

Who vs What:
 weights summing to 100

The desk is by far the worst, and the Stow Step is the best, but not by much

HoQ: Specification Ranking

	Weight	Under 4 usage steps	Low storage volume	Rung spacing	Angled with floor	Supported Weight	Installation time	Lifespan	Rung width	Meets OSHA	Cost
	lbs	Y/N	ft ³	in	deg	lbs	min	years	in	Y/N	\$
	↓	<-->	↓	<-->	<-->	↑	↓	↑	<-->	<-->	↓
Importance	333	389	372	182	234	528	261	162	312	522	162
Importance (Ranking)	5	3	4	9	8	1	7	10	6	2	10

Rank 1: Supported weight

- use **strong materials** / strong supporting structures

Rank 2/3: Safety and Simplicity

- **Round square edges**
- limit pinching zones
- Limit telescoping sections

Rank 8/9: Floor Angle and Rung Spacing

- consumers didn't verbalize the need --> **basic features in Kano's model**
- Must include an angle with the floor
- Rungs must be spaced for easy climbing

HoQ: Critical Specifications

To be competitive and ensure we design a unique solution we are aiming for the best specifications from each benchmark

- Support at least 300 pounds to be viable alternative
- Angle of 75 degrees to match standard ladder
- \$90 cost to undercut standard ladder and compete with Stow Step

	How (ES)										
	Weight	Under 4 usage steps	Low storage volume	Rung spacing	Angled with floor	Supported Weight	Installation time	Lifespan	Rung width	Meets OSHAA	Cost
	lbs	Y/N	ft^3	in	deg	lbs	min	years	in	Y/N	\$
	↓	<-->	↓	<-->	<-->	↑	↓	↑	<-->	<-->	↓
Bedloft built in ladder	N/A	y	0	6	90	1000	0			y	0
Desk	100	y	10	15			5			y	0
Regular Ladder	20	y	3	8	75		2		16	y	100
"Stow Step"	10	y	0	8	90	300	10		10	n	50
Target (Delighted)	25	y	2	8	75	300	10	50	18	y	90
Threshold (Disgusted)	65	n	4	12	60/90	200	30	10	16	n	150

Problem Definition Phase Schedule

JS^2	Week 1					Week 2					Week 3					Week 4					Week 5				
Project Tasks and Milestones	M	T	W	R	F	M	T	W	R	F	M	T	W	R	F	M	T	W	R	F	M	T	W	R	F
Team organization			█	█	█																				
Project selection			█	█	█	█	█	█																	
Customer Research								█	█	█	█	█	█												
Intellectual property											█	█	█	█											
Personas														█	█	█	█	█	█						
Develop HoQ														█	█	█	█	█	█	█	█	█	█		
Human Centered Design																			█	█	█	█	█	█	
Paper #1 Introduction														█	█	█									
Paper #1														█	█	█	█	█	█	█	█	█	█	█	█
Oral Report #1																							█	█	█

Concept Generation Phase Schedule

JS^2	Week 6					Week 7					Week 8					Week 9					Week 10				
Project Tasks and Milestones	M	T	W	R	F	M	T	W	R	F	M	T	W	R	F	M	T	W	R	F	M	T	W	R	F
Group Eval #1	█	█	█																						
Paper #1	█	█	█																						
Functional Decomposition			█	█	█	█	█	█	█																
Generate Concepts			█	█	█	█	█	█	█	█	█														
Bill of Materials										█	█	█	█	█	█	█	█								
Paper #2 Plan	█	█	█	█	█	█	█	█	█																
October Break										█	█	█													
Financial Analysis																	█	█	█						
Low Fidelity Prototype																		█	█	█	█	█			
Oral Report #2	█	█	█	█	█	█	█	█	█	█	█	█	█	█	█	█	█	█	█	█	█	█	█	█	
Paper # 2										█	█	█	█	█	█	█	█	█	█	█	█	█	█	█	

Design Realization Phase Schedule

JS^2	Week 11					Week 12					Week 13					Week 14					Week 15				
Project Tasks and Milestones	M	T	W	R	F	M	T	W	R	F	M	T	W	R	F	M	T	W	R	F	M	T	W	R	F
Group Eval #2	█	█	█																						
engineering drawings			█	█	█	█	█	█																	
modeling/final prototype			█	█	█	█	█	█	█	█	█	█	█	█	█	█	█	█	█	█	█	█	█	█	
poster	█	█	█	█	█	█	█	█	█	█	█	█	█	█	█										
Final oral presentation			█	█	█	█	█	█	█	█	█	█	█	█	█	█	█	█	█	█	█	█	█	█	█
Group Eval #3																									█
final paper			█	█	█	█	█	█	█	█	█	█	█	█	█	█	█	█	█	█	█	█	█	█	
final presentation													█	█	█	█	█	█	█	█	█	█	█	█	█